



XC998 石材叉装机

技术规格书

Technical specifications of XC998 stone loader



徐工铲运机械事业部

XCMG Earthmoving Machinery Business Unit

XC998 石材叉装机性能特点与配置说明

Performance Characteristics and Configuration Description of XC998 Marble Wheel Loader

XC998 轮式大块物料搬运机是利用徐工 XC9 系列大吨位国际化研发平台，全力打造具有国际先进水平的石材搬运产品。该机型动力强劲、坚固可靠、安全舒适，保养便利，并针对石材叉装堆料、撬料等工况需求进行专项提升，是各大采石场的首选生产搬运设备。

The XC998 marble loader is an internationally advanced stone handling product built on the basis of the XC9 series large-tonnage international platform of XCMG. This model is powerful, sturdy and reliable, safe and comfortable, and easy to maintain. It has been specially upgraded for stone fork loading, stacking, skidding working conditions. It is the preferred handling machine for quarry customers..The main features are as follows:

一、主要性能与特点 Main performance and characteristics

动力传动系统 Transmission system

1. 发动机 Engine

康明斯电喷、涡轮增压、空空中冷发动机，电启动、电熄火，排放满足欧美排放法规欧 V 阶段要求；采用“旋流式”三级空滤，适应采石场重粉尘使用工况；深度提升的动力匹配技术，确保动力性能达到最佳状态，提升满载爬坡需求。

Cummins EFI, turbocharged, air-to-air cooling engines meet Euro V emissions. The "swirling" three-stage air filter is adopted to adapt to the heavy dust conditions in the quarry; the focus is on improving and optimizing the power matching technology to ensure the best power performance and improve the climbing ability under full load.

2. 变速箱 Transmission

双变采用进口 ZF-4WG310 “手自一体”电控变速箱，档位前四后三，具有 KD 档、ICCO、空档启动保护、变速档位锁定等功能；大能容、具有带增扭导轮自由轮变矩器，传递效率高，有效提高工作效率和经济性；工作装置操控手柄集成 F-N-R 换挡功能，可快速方便地改变整机行驶方向，降低驾驶疲劳强度。

It adopts ZF-4WG310 electronically controlled gearbox, with four gears forward and three reverse, with functions such as KD, ICCO, neutral start protection, gear

shifting gear locking, etc.; High transmission efficiency, improve work efficiency and economy; the control handle of the work device integrates the F-N-R shift function, which can quickly and easily change the driving direction of the whole machine and reduce driving fatigue.

3. 驱动桥 Drive axle

ZF 湿式驱动桥，前桥配有差速锁止功能，免维护多片湿式制动片，延长了桥的使用寿命；后桥中心摆动，减少了附加扭矩及外载荷对传动系统的冲击，键块“三段式”式工程机械传动轴，抗冲击能力强，动力传递可靠性高。采用 29.5R25 低压宽基越野轮胎，滚动阻力小且有效减少轮胎磨损，加之后桥可绕中心摆动，具有良好的越野性能和通过性能，完全适应在崎岖不平的路面上行驶和作业。

ZF wet drive axle, the front axle is equipped with differential lock function, maintenance-free wet brake pads, which prolongs the service life of the axle; the center swing of the rear axle reduces the impact of additional torque and external load on the transmission system, "three-stage "type construction machinery drive shaft, strong impact resistance and high reliability of power transmission. Using 29.5R25 low-pressure wide-base off-road tires, the rolling resistance is small and the tire wear is effectively reduced. The rear axle can swing around the center, which has good off-road performance and passing performance, and is fully suitable for driving and working on rough roads.

4. 液压系统 Hydraulic system

整机采用负载敏感全变量液压系统，工作、转向按载荷需求提供压力和流量，消除溢流损失，节能降耗；流量放大转向系统，操作轻便灵活，降低工作疲劳度，先柔后刚双重限位技术，减少转向冲击，进一步改善操作舒适性并提升整机可靠性。

高置油箱，改善泵吸油环境和液压油污染程度，延长泵和液压油使用周期。

第二转向辅助系统能够确保整机在失去动力情况下被拖车牵引时仍具有转向功能，提升整机行驶安全可靠。

The whole machine adopts a load-sensitive full-variable hydraulic system to eliminate overflow loss and save energy and reduce consumption. The flow amplification steering system makes steering light and flexible, reducing work fatigue.

The steering system uses the limit stop valve first, and then the mechanical limit, so as to reduce the steering shock, improve the operating comfort and improve the reliability of the whole machine.

The high oil tank improves the pump's oil absorption capacity, reduces the pollution of hydraulic oil, and prolongs the service life of the pump and hydraulic oil.

The second steering assist system can ensure that the whole machine still has a steering function when it is towed by a trailer under the condition of loss of power, improving the safety and reliability of the whole machine..

液压驱动电控智能散热系统，根据各系统散热需求风扇自行调整转速，节能高效，性能最优并具有手动反转功能便于散热器清理，减少日常维护保养时间。

Hydraulic drive & electronically controlled intelligent cooling system, the fan adjusts the speed according to the cooling requirements of each system, energy saving, high efficiency, optimal performance, and the manual reversing function to facilitate radiator cleaning and reduce daily maintenance time.

制动系统 Braking System

全液压双回路湿式行车制动和钳盘式停车制动，前后桥制动相互独立，具有低压报警提示，紧急制动与停车制动二合一，确保作业行车安全；复合制动控制技术，最大程度减少制动时的冲击和热量发生，优良的制动元件进一步提升制动系统可靠性；湿式多盘式制动器为全密封结构，能有效防止粉尘进入，延长系统寿命。

Full hydraulic dual-circuit wet braking system, the front and rear axle brakes are independent of each other, with low pressure alarm prompt, emergency braking and parking brake combined to ensure driving safety. The compound braking control technology minimizes the shock and heat generation during braking, and the excellent braking elements further improve the reliability of the braking system. The wet multi-disc brake is a fully sealed structure, which can effectively prevent dust and prolong the life of the system.

驾驶室和操纵系统 Cab and control system

徐工新型 FOPS&ROPS 微增压驾驶室，空间大，密封性好，前部两侧玻璃整体式结构，减少视线分割，视野开阔；气囊减震座椅、阻尼器和减振绞架等核心部

件确保驾驶舒适性；智能温控大功率冷暖空调，“立体式”出风布置，操作环境舒适、惬意，让您充分享受每一次愉悦的工作驾驶以提高生产效率！

XCMG's new FOPS&ROPS pressurized cab has large space and good sealing performance. The glass integral structure on both sides of the front end reduces sight separation and provides a wide field of vision. Air suspension seats with dampers and vibration-damping winches ensure driving comfort. Intelligent temperature control high-power heating and cooling air conditioner, optimized air outlet layout, comfortable operating environment, allowing you to fully enjoy every pleasant work and driving to improve production efficiency!

车架 Frames

整机结构布置科学合理，载荷重心靠近前轮，承载受力平衡性能好，作业安全可靠；

结构件通过有限元分析改进，抗过载能力强，能够承受转弯工况下的反复扭力与冲击；

关键结构件采用一体式、箱型结构，保证重载叉装作业需求；

上、下铰接销处采用双圆锥滚子轴承，增大承载能力，提高行驶稳定性；

粉末静电涂装及特殊防腐技术解决锈蚀难题；

重型积放链配送方式，减少运输污染，提升部件清洁度保证装配配合精度。

The structure of the whole machine is scientific and reasonable, the center of gravity of the load is close to the front axle, the load-bearing force balance performance is good, and the operation is safe and reliable.

The structural parts are improved through finite element analysis, with strong anti-overload capability, and can withstand repeated torsion and impact under turning conditions.

The key structural parts adopt an integrated, box-type structure to ensure the requirements of heavy fork loading conditions;

Powder electrostatic coating and special anti-corrosion technology solve the rust problem.

The heavy-duty accumulation and release chain distribution method reduces transportation pollution, improves the cleanliness of components, and ensures the

accuracy of assembly and coordination.

工作装置及铲斗 Working device and bucket

工作连杆经最优设计，采用双摇臂、短拉杆 Z 型反转六连杆结构，视野宽；加大举升油缸、具有提升力量大、举升平稳等优越的作业性能；动臂采用高强度板材，安全系数大；

The Z-link system has been optimally designed, and adopts the double rocker arm and short tie rod Z-shaped reversed six-link structure, with a wide field of view;

Enlarge the lifting cylinder, which has the superior performance of large lifting force and stable lifting;

The boom is made of high-strength sheet metal, with a large safety factor;

集中润滑系统 Centralized lubrication system

集中润滑系统，性能卓越质量可靠。利用适当的泵压，定时、定量的泵送润滑脂到各润滑点，保证各摩擦副维持可靠和足量的油膜，使其持久正常运行。

The centralized lubrication system has an excellent performance and reliable quality. Use proper grease pump to lubricate each point regularly and quantitatively to ensure that each friction pair maintains a reliable and sufficient oil film to make it run normally.

自动控制器带有计时器，机器启动后开始计时，当润滑周期达到设定值时则开始输送润滑脂。如果机器中途停机则 CPU 将数据自动保存，下次启动时不再重新计时，而对时间进行累计，以免因工作时间小于周期而造成润滑不足。注射周期及注油时间均可在泵的控制板上进行调节。

The automatic controller has a timer, which starts timing after the machine is started, and starts to deliver grease when the lubrication cycle reaches the set time. If the machine stops halfway, the CPU will automatically save the data, and the time will not be re-timed when the machine is started next time, and the time will be accumulated to avoid insufficient lubrication due to the working time being less than the cycle. The lubrication cycle and oil filling time can be adjusted on the control panel of the lubrication pump.

维修与保养 Maintenance

机罩整体后翻，便于维护发动机机油、柴油等滤芯更换；

单层大波距散热器+可旋开空调散热器，便于清理散热器的每一处堵塞物；
电气保险盒集中布置，便于排查、检修、判断电气部件工作状态；
集中测压、集中放液等功能设计方便日常保养维护；

The backward hood is easy to replace the engine oil filter and diesel filter;

Single-layer large space radiator + can be unscrewed air conditioner radiator, easy to clean every blockage of the radiator;

The electrical fuse box is centrally arranged, which is convenient for checking, overhauling and judging the working status of electrical components;

The centralized pressure measurement and centralized liquid discharge function are designed to facilitate daily maintenance.

倒车影像及 GPS 技术 Reversing camera and GPS function

先进的倒车后视装置给驾驶员提供了广阔的后视工作视野，给安全作业带来可靠的保障。同时，GPS 可以实现远程数据诊断功能，随时监测到机器的各项技术参数及作业情况，为维护保养带来良好的数据支持。

The advanced reversing rear-view device provides the driver with a broad rear view working field of vision, which provides reliable guarantee for safe operation. At the same time, GPS can realize remote data diagnosis function, monitor various technical parameters and operating conditions of the machine at any time, and bring good data support for maintenance.

二、主要技术参数 The main technical parameters:

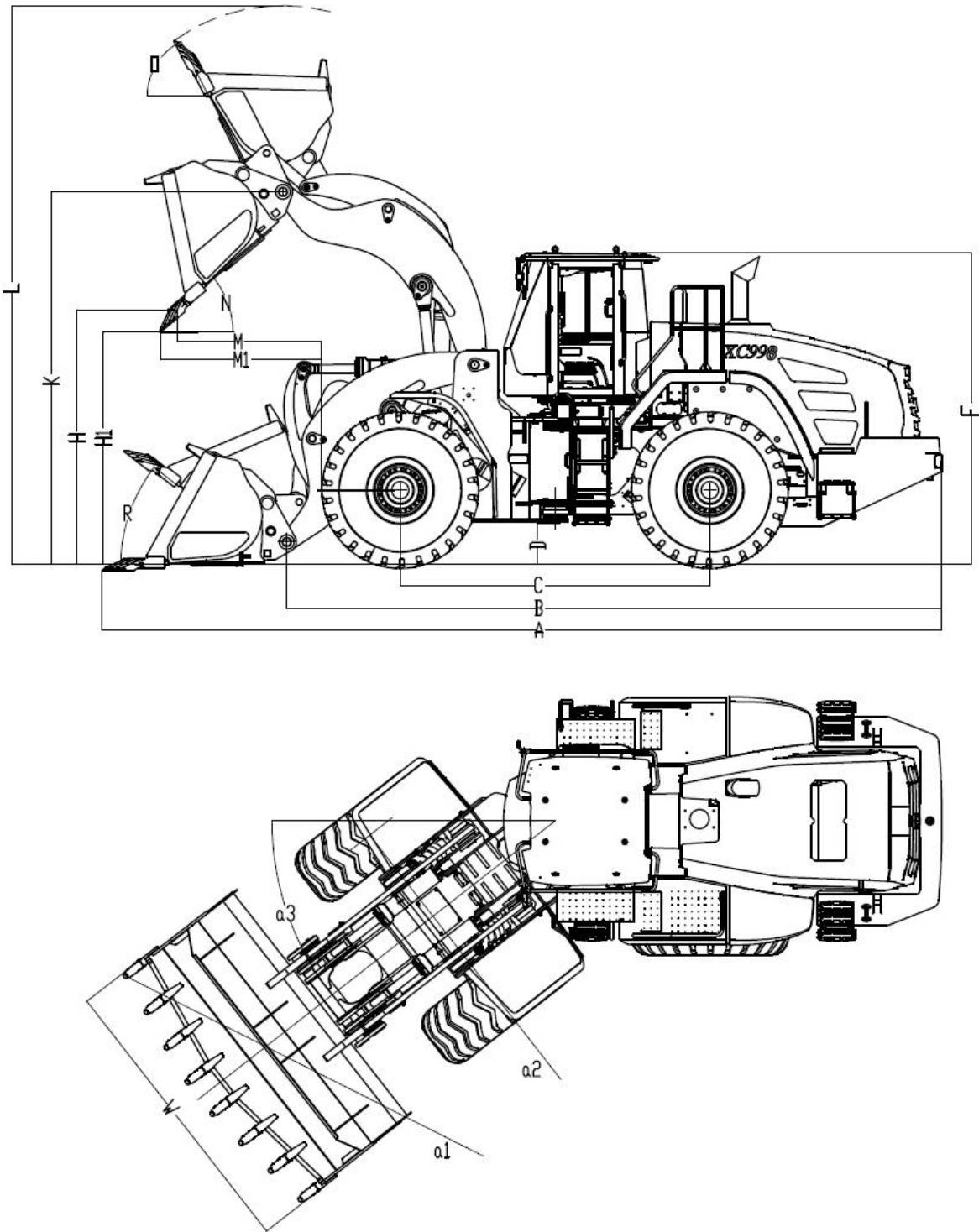

项目 Item	参数 Parameter
额定斗容量 Rated bucket capacity (m ³)	4.8(V Shape)
额定载重量 Rated load capacity (kg)	9000
整机工作质量 Operating mass (kg)	35000

卸载高度 Dumping height (mm)	H	2780
	H1	3050
卸载距离 Dumping reach (mm)	M	1920
	M1	1750
铰销高 Maximum lift position hinge pin height (mm)	K	4460
最大举升高度 maximum lift height(mm)	L	6700
轴距 Wheelbase (mm)	C	3700
轮距 Wheel tread (mm)		2460
铰接销离地间隙 Ground clearance(mm)	D	485
最小离地间隙 Minimum ground clearance (mm)		350
整机长度 Overall length (mm)	A	10040
主机长度 Overall length without bucket (mm)	B	7850
整机高度 Overall height (mm)	F	3770
铲斗宽度 Bucket width (mm)	W	3500
主机宽度 Machine width (without bucket) (mm)		3350
卸料角 Dump angle(°)	N	40
高位收斗角 Buckte angle(max lift height) (°)	O	63
地面收斗角 Buckte angle(Ground) (°)	R	38
掘起力 Max. breakout force (kN)		≥270
牵引力 Max. traction force (kN)		265
转向角度 Steering angle (°)		±38
转弯半径 Turning radius	a1	≤7850
	a2	≤6610
动臂提升时间 Lifting time of boom (S)		≤12.5
三项和时间 Total cycling time (S)		≤23
倾翻载荷 Tipping load (kg)	对直状态 Straight	32087
	全转向 At full turn	27495
发动机 Engine	额定功率 Rated power (kW)	265
	额定转速 Rated speed (r/min)	2000
轮胎型号 Tire specification		29.5R25
最大行驶速度 Maximum traveling speed (km/h)	前进/后退一档 1 st F/R	6/6
	前进/后退二档 2 st F/R	11.4/11.4
	前进/后退三档 3 st F/R	24.2/24.2
	前进四档 4 st F/-	33

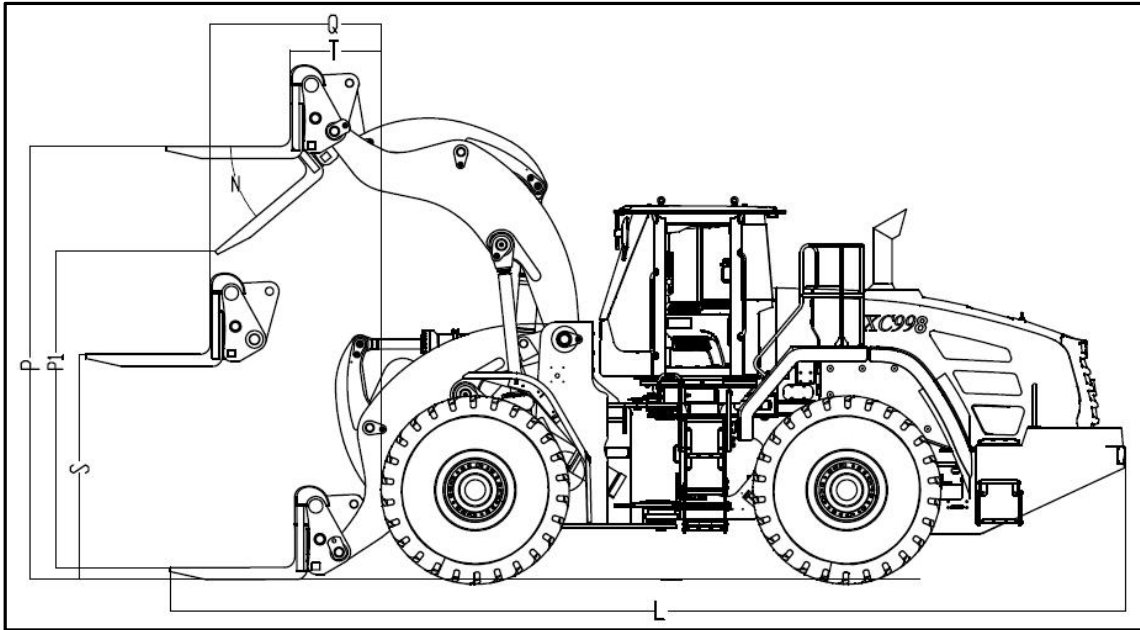

项目 Item	参数 Parameter	
整机长度 Overall length (mm)	L	9600
最大举升高度 Max. Lifting height (mm)	P	4300
最大举升高度时托架前沿距前轮距离 Max. fork distance (mm)	T	830
动臂平伸举升高度 Max. fork height in reach (mm)	S	2210
动臂平伸举升时托架前沿距前轮距离 Max. fork distance at its highest position	Q	1630
高位卸料时卸高 Dumping height (mm)	P1	3225
掘起力 Maximum breakout force (kN)		≥ 300

载荷曲线图 Load curve graph:

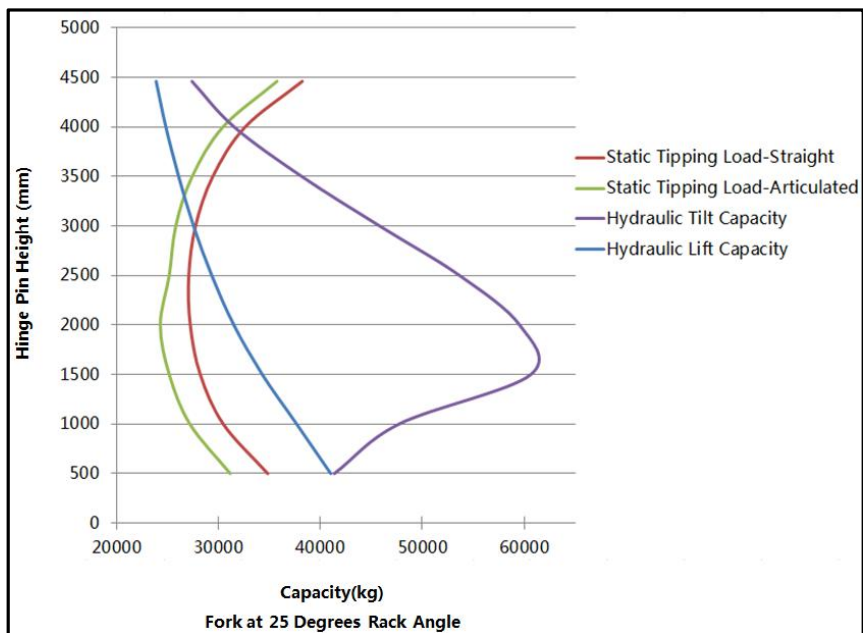

三、主要部件配置 Main component configuration

序号	名称	规格	制造厂家
1	发动机 Engine	X12	康明斯 CUMMINS
2	变速箱 Gearbox	4WG310	德国采埃孚 ZF
3	驱动桥 Drive axle	MT-L3125II/3115II	德国采埃孚 ZF
4	工作泵 Working pump	A10VO110DFR1	德国力士乐 Rexroth
5	转向泵 Steering pump	A10VO110DFR1	德国力士乐 Rexroth
6	先导阀 Pilot valve	4THF6K14-20/2TH6	德国力士乐 Rexroth
7	分配阀 Multi-way valve	M6-1488-30/3M6-22H	德国力士乐 Rexroth

注：整机配置冷暖空调。

Note: The whole machine is equipped with heating and cooling air-conditioner.