

XD140VT



XD140VT

Combination Vibratory Roller

XD140VT is suitable for compaction of soil and asphalt pavement in narrow areas such as sidewalks, parking lots and residential roads, it can also be used for compacting thin stable soil layering, which is an ideal compaction equipment for asphalt surface laminating in municipal maintenance and high-speed pipe maintenance.

Performance and characteristics

- 60Hz high frequency vibration, 920mm large diameter roller, effectively improve the quality of compaction.
- Large-capacity water tank, interval controlled sprinkling for prolonged operation.
- Drum and articulated frame are maintenance-free during the whole life cycle.
- Sliding operation mechanism for more convenient edge compaction.

Main dimensions

Unit: mm

Model	L	L1	W	W1	H	H1	H2	S	D	D1
XD140VT	2910	1980	1515	1380	1980	2720	350	16	920	810

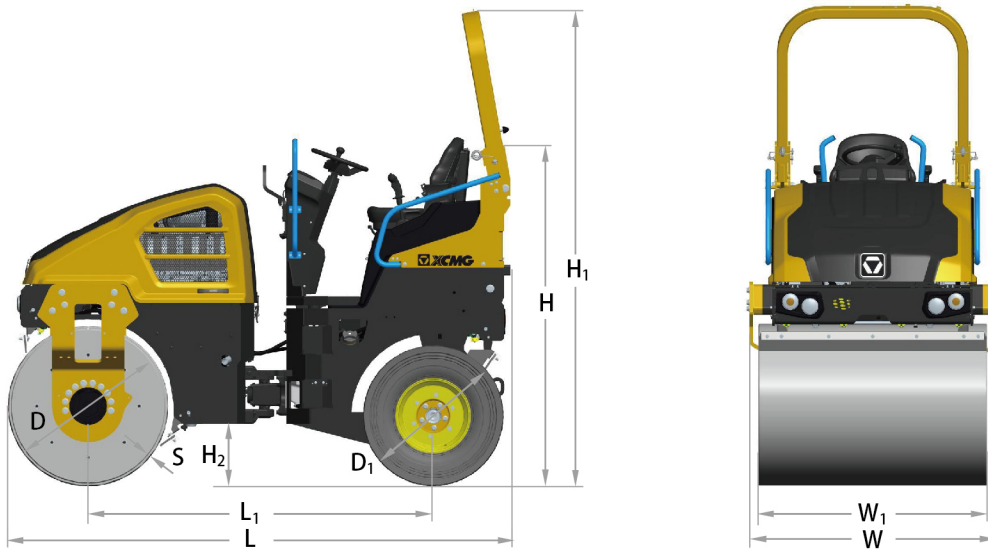

Main specifications

Item	Content	Unit	XD140VT
Weights	Operating weight	kg	4000
	Maximum operating weight	kg	4100
	Front axle weight	kg	2100
	Rear axle weight	kg	1900
	Static linear load	N/cm	152
Maneuverability	Operating speed	km/h	0-12
	Gradeability	%	30
	Minimum turning radius(outer)	mm	4100
	Minimum ground clearance	mm	350
	Wheel base	mm	1980
	Steering angle	°	±32
Compaction parameters	Oscillation angle	°	±8
	Vibration frequency	Hz	53/60
	Nominal amplitude	mm	0.5
	Excitation force	kN	42/53
	Drum diameter	mm	920
Engine	Drum width	mm	1380
	Model	-	V2403
	Emission		EU Stage V/EPA TIER4f
	Rated power	KW	33.6
	Rated speed	r/min	2400
Capacities	Fuel tank	L	55
	Water tank	L	235+45