



SOLID TO SUCCEED

XCMG European Sales and Services GmbH

Add: Europark Fichtenhain B4, 47807 Krefeld, Germany

E-mail: info@xcmg-ess.de



WWW.XCMGGLOBAL.COM
XCMG OFFICIAL WEBSITE

XCMG

XT2506E
TELEHANDLERS

MAX. LIFTING HEIGHT 5.85m

MAX. LIFTING CAPACITY 2500kg

BATTERY 309V/150AH

XCMG
SOLID TO SUCCEED

PRODUCT PARAMETER

ITEM	PARAMETER
Dimension	
Overall length (without fork)	3930mm
Overall width (stabilizers stowed)	1835mm
Overall height	1975mm
Wheelbase	2300mm
Wheel distance	1500mm
Min. ground clearance	330mm
Fork dimension	1200x122x40mm
Weight and tires	
Total weight (with fork)	5100kg
Tire specification	12-16.5
Performance	
Max. lifting capacity	2500kg
Load center to carriage	500mm
Max. lifting height	5.85m
Lift capacity at maximum height	2000kg
Max. outreach	3.43m
Lift capacity at maximum reach	860kg
Boom up	≤7.5s
Boom down	≤5.5s
Boom extend	≤4.8s
Boom retract	≤3.5s
Fork tilt down	≤3.2s
Fork tilt up	≤3.2s
Boom luffing range	-2° ~ 68°
Carriage tilt range	-12° ~ 117°
Max. traveling speed	24.9 km/h
Max. traction force	≥32kN
Min. turning radius	≤3310 mm
Frame leveling angle	±9°
Power System	
Traveling motor voltage	309V
Maximum power of traveling motor	70kw
Work motor voltage	309V
Maximum power of working motor	50kw
Battery specification	309V/150AH (standard) 309V/228AH (optional)
Charger specification	380VAC/32A (slow) 200A (fast)
Transmission System	
Numbers of gears (forward/backward)	1/1
Transmission type	Motor drive
Steering mode	4-wheel steering
Drive mode	4x4
Hydraulic System	
Hydraulic pump type	Piston pump
Hydraulic system pressure	28Mpa
Hydraulic system flow	100L/min
Hydraulic oil tank volume	100L

STANDARD CONFIGURATION

Cabin	
FOPS and ROPS certification	
Heating and cooling air conditioning	
Air suspension seat	
Seat belt not fastened detection function	
Multifunction proportional handle	
Anti-tip system	
Scram switch	
Rotating alarm lamp	
The reverse buzzer	
Astern image	
8 "main display +4.3" secondary display	
Square adjustable steering wheel	
Windshield wiper	
megaphone	
radio	
Cigarette lighter	
Cup holder	
Crash hammer	
extinguisher	
Power rearview mirror	
Hand rest	
Bluetooth phone	
Phone stand	
medikit	
Electrically heated glass	
Two position shift	
One click pressure relief	
Chassis	
Wet brake system	
Multi-mode steering function	
Rear axle midposition detection function	
Boom	
Length Angle real-time feedback system	
Fork leveling automatically	
Manual quick change	

OPTIONAL CONFIGURATION

Boom Attachment Harness
Attachment Fuel Port Extension
Foam filled tires
Bi-Color Warning Lights, License Plate Lights

OPTIONAL ATTACHMENTS

Forks
Bucket
Hooks

LOAD CHART

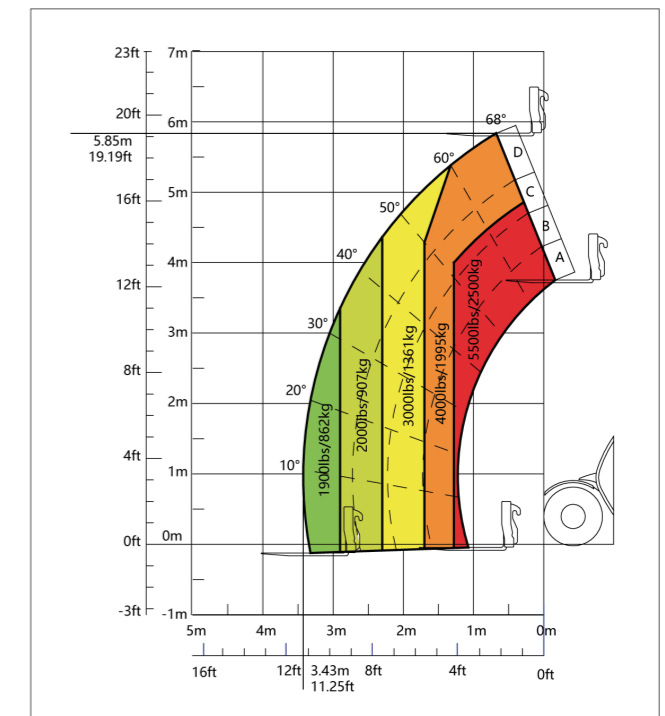

DIMENSION

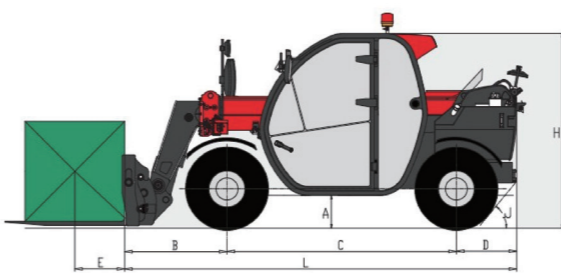
	A Min. ground clearance	330mm
	B Front overhang	1025mm
	C Wheel base	2300mm
	D Rear overhang	605mm
	E Load center to carriage	500mm
	L Overall length	3930mm
	H Overall height	1975mm
	M Overall width	1835mm
	I Approach angle	-
	J Departure angle	50°